



## Peelers Vegetable Peeler, 25 kg - Abrasive Plate

ITEM # \_\_\_\_\_

MODEL # \_\_\_\_\_

NAME # \_\_\_\_\_

SIS # \_\_\_\_\_

AIA # \_\_\_\_\_



603649 (DT25EF350)

25 kg vegetable peeler. Stainless steel body with abrasive plate and abrasive cylinder. Suitable for 100 to 500 meals

603650 (DT25EF150)

25 kg vegetable peeler. Stainless steel body with abrasive plate and abrasive cylinder. Suitable for 100 to 500 meals

### Short Form Specification

Item No. \_\_\_\_\_

Constructed in stainless steel. The removable rotating plate and the cylinder are covered with a removable rotating plate covered in very resistant abrasive material (silicon carbide). Fully opening polycarbonate lid. An interlocking safety magnetic device will stop the machine when the unloading door is opened. Flat and waterproof touch button control panel with timer. The electronic controls and motor have IP55 protection.

Supplied with abrasive plate and abrasive cylinder for hard vegetables peeling.

### Main Features

- Suitable for 100-500 meals per service.
- Removable rotating plate covered in very resistant abrasive material (silicon carbide).
- Peels are reduced to small pieces to facilitate drainage process.
- Supplied with:
  - abrasive plate and abrasive cylinder as standard
- Timer with countdown display.
- Pulse function to control the unloading operation.
- Safety device stops the machine from operating with unloading door open.

### Construction

- Complete stainless steel construction.
- IP55 waterproof touch button control panel.
- Transparent BPA free cover.

### Included Accessories

- 1 of Abrasive plate for 25 kg vegetable peeler PNC 653506

### Optional Accessories

- Mobile trolley with filter tray for 25 kg peeler PNC 653302
- Abrasive plate for 25 kg vegetable peeler PNC 653506
- Waste dilution unit for 25 kg vegetable peeler PNC 653509

APPROVAL: \_\_\_\_\_





# Peelers Vegetable Peeler, 25 kg - Abrasive Plate

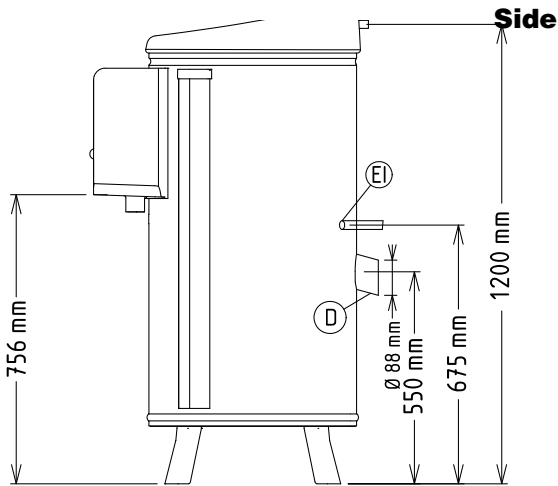
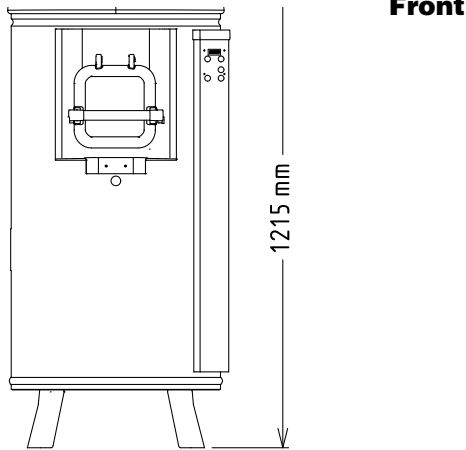

- CW1 = Cold Water inlet 1 (cleaning)
- D = Drain
- EI = Electrical inlet (power)

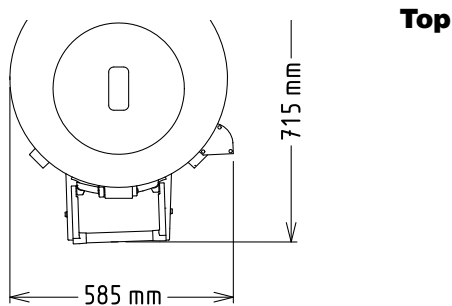

## Electric

### Supply voltage:

603649 (DT25EF350)	220-240/380-415 V/3 ph/50 Hz
603650 (DT25EF150)	220-240 V/1N ph/50 Hz

### Electrical power max.:

603649 (DT25EF350)	0.9 kW
603650 (DT25EF150)	1.1 kW

### Total Watts:

603649 (DT25EF350)	0.9 kW
603650 (DT25EF150)	1.1 kW

## Capacity:

Performance (up to):	400 - kg/hour
Capacity:	25 kg

## Key Information:

External dimensions, Width:	585 mm
External dimensions, Depth:	785 mm
External dimensions, Height:	1215 mm
Shipping weight:	
603649 (DT25EF350)	90 kg
603650 (DT25EF150)	103 kg



## Peelers Vegetable Peeler, 25 kg - Abrasive Plate

The company reserves the right to make modifications to the products without prior notice. All information correct at time of printing.